

# ONE

## SAT / 118 / Home

REF. 2844 / 2845 / 2849

Programmable multichannel amplifier



# Contents

## **30 General safety instructions**

- 30 Types of notices
- 31 Basic safety instructions

## **32 Introduction**

- 33 General description
- 33 Main features
- 34 General equipment use

## **36 Equipment installation and configuration**

- 36 Installation
- 36 Power connection
- 37 Quick menu guide
- 38 Language selection
- 38 Manual setting
- 41 Advanced settings
- 43 Self-installation

## **45 Maintenance**

- 45 Equipment care
- 45 Troubleshooting

## **46 Technical specifications**

- 46 ONE 118 Model (AFP-201)
- 47 ONE SAT Model (AFP-292)
- 48 ONE Home Model (AFP-HOME)

## **49 Technical annex**

## **50 Warranty**

## **51 Equipment recycling**

## **52 CE Certificate**

# General safety instructions

- Read all of this user manual carefully before plugging in the equipment.
- Always have these instructions to hand during installation.
- Follow all of the instructions and safety notices regarding equipment handling.

## Types of notices

The meaning of the safety notices used in this manual are described below.



### DANGER OF DEATH OR INJURY

This safety notice indicates a possible danger for the life and health of people. Not following these instructions may lead to serious consequences to health and may even cause fatal injuries.



### RISK OF EQUIPMENT DAMAGE

This safety notice indicates a possible dangerous situation. Not following these instructions may lead to the equipment being damaged.



### NOTE

This type of notice is a note containing applicable advice and useful information for optimum use of the equipment.



### HANDLING THE INSIDE OF THE EQUIPMENT IS FORBIDDEN

This notice forbids any work that may affect the working order of the equipment or its warranty.



### DO NOT DISPOSE OF AS URBAN WASTE

This type of notice indicates that the equipment must not be disposed of as unselected urban waste.

## Basic safety instructions



### DANGER OF DEATH OR INJURY

- Do not install the equipment during an electrical storm. This could lead to electrostatic discharge from lightning.
- Do not open the equipment. This could lead to electric discharge.



### RISK OF EQUIPMENT DAMAGE

- The equipment must be appropriately ventilated. Install the equipment in a dust-free location. Do not place the equipment in a location where the ventilation slots are covered or blocked. Install the equipment in a location with at least 20 cm around it free of other objects.
- Do not expose the equipment to rain or moisture. Install the equipment in a dry location with no infiltration or condensation of water. Should a liquid enter the equipment, disconnect it immediately from the mains.
- Keep the equipment away from flammable objects, candles and anything that may cause a fire.
- Connect the equipment to an easily accessible power socket. In the event of an emergency, it will then be possible to quickly unplug the equipment.
- Do not expose the equipment to sources of heat (sun, heating, etc.).

# Introduction

## General description

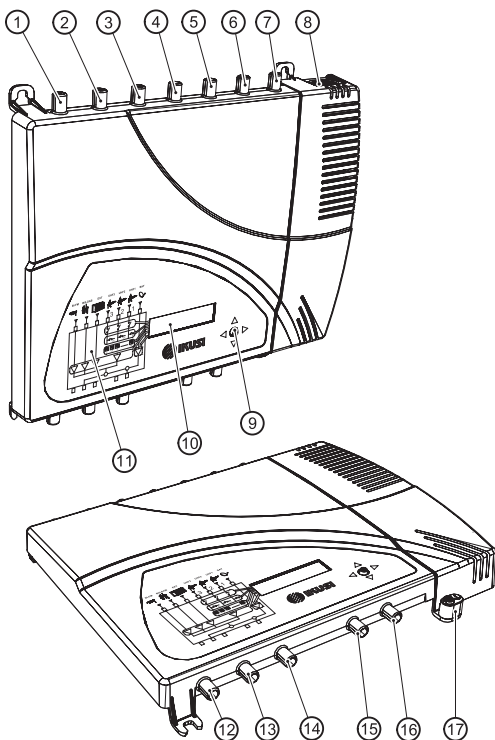

### KEY

- ① BI-FM input
- ② BIII-DAB input
- ③ VHF-UHF/EXT input \*
- ④ UHF3 input
- ⑤ UHF2 input
- ⑥ UHF1 input
- ⑦ SAT-IF1 input \*
- ⑧ Mains connector
- ⑨ Control button
- ⑩ Screen (LCD)
- ⑪ Front panel with cluster map
- ⑫ SAT-IF2 input with no amplification \*
- ⑬ Output 2; TV+SAT2 \*
- ⑭ Output test 2\*
- ⑮ Output test 1
- ⑯ Output 1; TV+SAT1 \*\*
- ⑰ Earthing

\* ONE SAT model only

\*\* In ONE 118 model TV only

## Main features

The ONE 118, ONE SAT and ONE Home models are programmable amplification headends designed to selectively filter analogue and digital UHF channels. Suitable for single-family and collective dwellings, they are the ideal solution for managing signals of different frequencies and bandwidths.

FM and VHF signals are also amplified. The ONE SAT model also amplifies satellite IF signals. Individual adjustment of each frequency filter, number of channels and automatic gain control allows for level equalize of selected channels.

### ■ Programming:

- Self-installation function.
- All settings are automatically memorised.
- No external programmer required, programmed directly from the headend.

- Reprogrammable as many times as required.
- 10 tuneable UHF filters with the capacity to process 1 to 5 channels each.
- Signal processing:
  - Terrestrial inputs with low noise figure (< 6 dB).
  - Satellite input with low noise figure (< 9 dB).
  - Automatic signal level equalisation.
  - Automatic gain control.
- Extra functions:
  - Internal configuration cloning with transferral to another equipment.
  - Equipment locking by security code.
- Dimensions : 290 mm x 240 mm x 20 mm
- Weight : 2 kg

The main features of the ONE 118 and ONE SAT models are described below.

### ONE 118 Model

Recommended for small and medium-sized installations made up of 10 UHF filters delivering an output level of 118 dB $\mu$ V.

- Inputs:
  - 5 terrestrial inputs = BI-FM, BIII-DAB, UHF1, UHF2, UHF3.
  - BI-FM gain = 35 dB.
  - BIII-DAB gain = 40 dB.
  - UHF gain = 55 dB.
- Outputs:
  - 1 TV output.
  - 1 Test output.
  - VHF/UHF output level = 118 dB $\mu$ V. <sup>1</sup>

<sup>1</sup> IMD3-60 dB, DIN 45004B (see channel reduction table in Technical Annex)

### ONE SAT Model

Recommended for small and medium-sized installations, comprising 10 UHF filters it includes one satellite input and two mixed television-satellite outputs. CTI compliant.

Compatible with UNICABLE™

- Inputs:
  - 6 terrestrial inputs= BI-FM, BIII-DAB, UHF1, UHF2, UHF3, VHF-UHF/EXT.
  - 2 satellite IF inputs.
  - BI-FM gain = 30 dB (2 outputs) or 35 dB (1 output).
  - BIII-DAB gain = 35 dB (2 outputs) or 40 dB (1 output).
  - UHF gain = 55 dB (2 outputs) or 60 dB (1 output).
  - VHF-UHF/EXT gain = 35 dB (2 outputs) or 40 dB (1 output).

- SAT1 gain = 40 dB.
- SAT2 gain = -1.5 dB.

■ Outputs (2 configurable outputs):

a)

- 2 TV+FI outputs
- 2 Test outputs
- VHF output level = 113 dB $\mu$ V.<sup>1</sup>
- UHF output level = 118 dB $\mu$ V.<sup>1</sup>
- FI/SAT output level = 116 dB $\mu$ V.<sup>2</sup>

b)

- 1 TV+FI output
- 1 Test output
- VHF output level = 118 dB $\mu$ V.<sup>1</sup>
- UHF output level = 123 dB $\mu$ V.<sup>1</sup>
- FI/SAT output level = 116 dB $\mu$ V.<sup>2</sup>

<sup>1</sup> Terrestrial: IMD3-60 dB, DIN 45004B

<sup>2</sup> Satellite: IMD3 -35dB, EN50083-3. See channel reduction table in Technical Annex

## ONE Home Model

Recommended for small installations made up of 10 UHF filters delivering an output level of 118 dB $\mu$ V.

■ Inputs:

- 2 terrestrial inputs = BI-FM, UHF1
- BI-FM gain = 2 dB.
- UHF gain = 40 dB.

■ Outputs:

- 1 TV output.
- 1 Test output.
- VHF/UHF output level = 113 dB $\mu$ V. <sup>1</sup>

<sup>1</sup> IMD3-60 dB, DIN 45004B (see channel reduction table in Technical Annex)

## General equipment use

Interaction with the equipment using the button and the interpreting of the instructions displayed on the LCD screen are described below. The programme includes a main menu formed by submenus that can be selected to modify the equipment operating settings.

### Instructions displayed on the LCD screen



This symbol is displayed when manual setting is selected. It refers to the clusters indicated on the panel.

---



This symbol is displayed in the manual setting menu. Visually locate it on the LCD screen and see the cluster map on the panel to see which of the 5 equipment clusters is selected.



This acronym is displayed in the main menu. Select it to go back to the language selection menu.



This symbol is displayed in manual settings and advanced settings and visually indicates the possibility of moving vertically.



This symbol is displayed in manual and advanced settings and always includes a numeric value and visually indicates the gain level.

This icon is displayed when the equipment lock is enabled when the equipment is switched on and after periods when the equipment is not in use.

## Vertical button movement



In the menus and submenus, move the button up or down to browse upwards and downwards position by position.

In the settings, move the button up or down to modify values position by position.



### NOTE

Keep the button pressed up or down to browse or to modify values more quickly.

## Horizontal button movement



In the menus, move the button to the left or the right to select and go back position by position.

In the settings, move the button to the left or the right to browse, select and go back position by position.



### NOTE

Keep the button pressed to the left or to the right to browse more quickly.

## Press button



In the menus, this selects the submenu.

In the submenus, this selects the setting.

In the settings, this selects the parameter value.



# Equipment installation and configuration

Only the LCD screen and the button are required to configure the equipment. Follow the steps below to install the equipment and configure the different parameters.

## Installation



### RISK OF EQUIPMENT DAMAGE

Mechanical handling of the equipment while it is switched on may lead to it being damaged. Do not plug the equipment into the mains before or during installation.

- 1) Fit and tighten the bolts and plugs securing the equipment to the wall.
- 2) Connect the coaxial cable from the aerial to the equipment.
- 3) Connect the coaxial cables from the outputs to the equipment.  
If only one of the 2 outputs is used, terminate the spare port with a 75Ω loadplug.

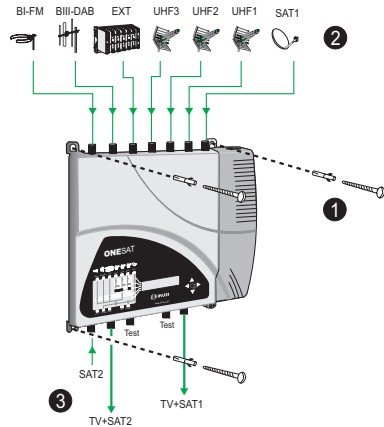

## Power connection



### DANGER OF DEATH OR INJURY

Incorrect equipment power connection may cause an electric shock. Follow the steps below for the electrical installation of the equipment.

- 1) Connect the ground cable.
- 2) Connect the power plug to the equipment mains connector.
- 3) Connect the power plug to the mains socket.

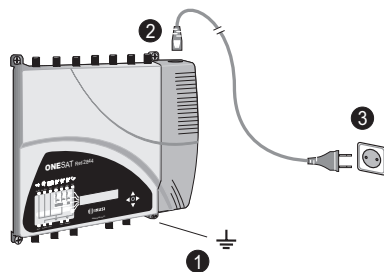

# Fast menu guide

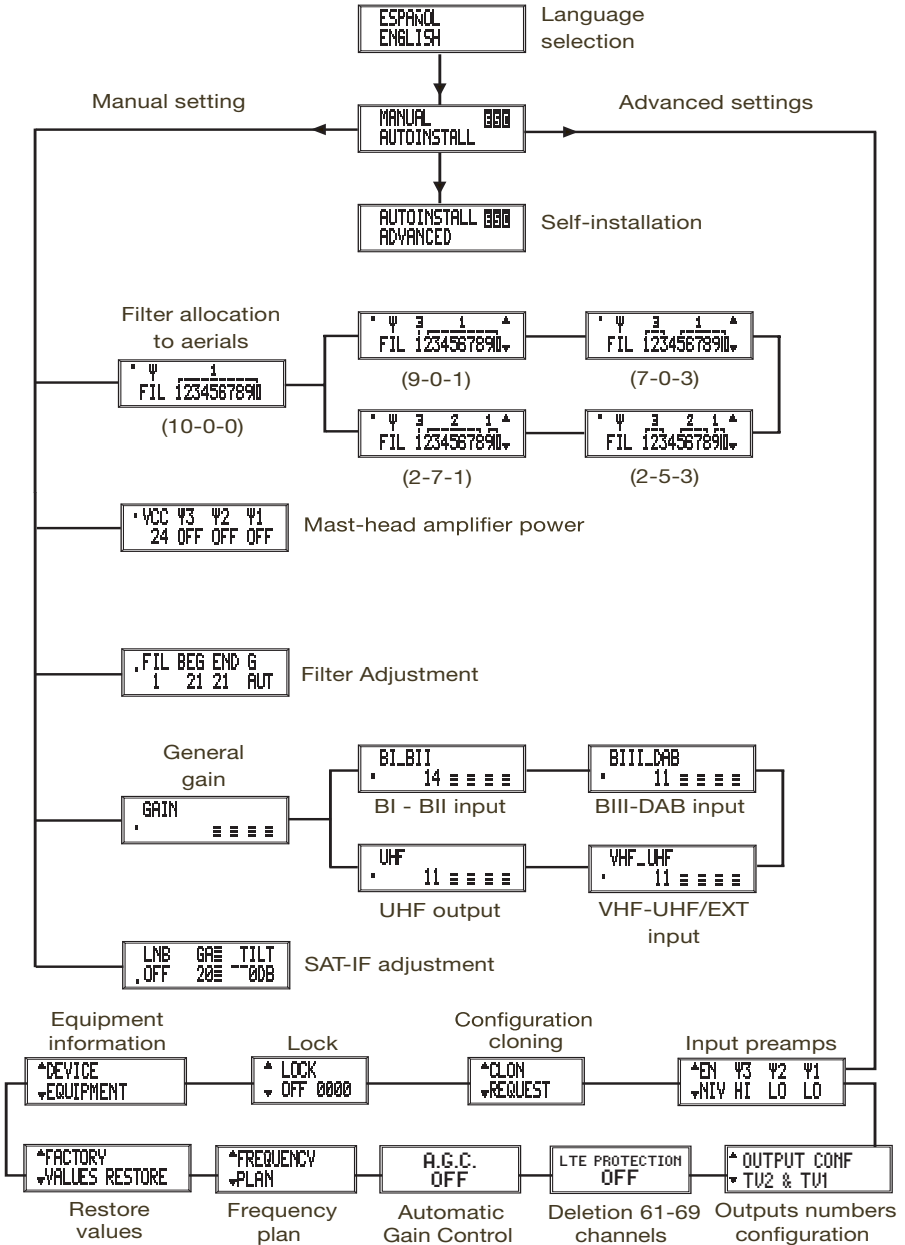

## Quick menu guide

### Language selection



#### NOTE

Over the following pages, the field locating and selection method is primarily indicated by the “vertical button movement” and “press button” icons. However, horizontal button movement can be used to locate and select fields, as indicated in the [General equipment use](#) section on Page 34.

#### NOTE

The equipment automatically accesses language selection a few sections after the welcome message is displayed. Language selection can also be accessed by going back from the main menu.

- 1) Locate and select the language: ESPAÑOL – ENGLISH – FRANÇAISE.
- 2) Access the main menu.



### Manual setting

- 1) In the main menu, locate and select MANUAL.



#### NOTE

The cluster map on the equipment panel indicates the cluster related to each sub-menu.



### Filter allocation to aerials



#### NOTE

There are five different configurations to distribute the 10 filters among the 3 aerials.

- 1) Locate and select the aerial filter configuration (the aerial distribution is displayed at the top of the screen and the 10 filters available are displayed at the bottom):

- For one aerial:

- a) Configuration (10 – 0 – 0)

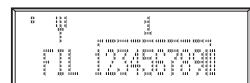

■ For two aerials:

b) Configuration (9 – 0 – 1)



```

Ψ 3 1
FIL 1234567890
  
```

c) Configuration (7 – 0 – 3)



```

Ψ 3 1
FIL 1234567890
  
```

■ For three aerials:

d) Configuration (2 – 5 – 3)



```

Ψ 3 2 1
FIL 1234567890
  
```

e) Configuration (2 – 7 – 1)



```

Ψ 3 2 1
FIL 1234567890
  
```

## Mast-head amplifier power configuration



### NOTE

Only where a mast-head amplifier is fitted to the aerial.

1) Locate and select the UHF input voltage: VDC, 24 / 12.



```

VDC Ψ3 Ψ2 Ψ1
24 OFF OFF OFF
  
```

2) Locate and select UHF input voltage enabling (ON) / disabling (OFF):

a) UHF3 input voltage: Ψ3, ON / OFF

b) UHF2 input voltage: Ψ2, ON / OFF

c) UHF1 input voltage: Ψ1, ON / OFF

## Filter adjustment

### Frequency configuration

1) Locate and select the filter to adjust:  
FIL, 1 – 10.



```

FIL BEG END G
1 21 21 AUT
  
```

2) Locate and select the filter start channel:  
BEG, 21 – 69.

3) Locate and select the filter end channel:  
END, 21 – 69.

**Gain configuration:**



**NOTE**

If AUT is selected (recommended), the AGC will try and maintain the output at factory preset level. If M is selected the AGC will maintain the output at the level you have set.



- 1) Locate and select the gain configuration mode AUT / M.



- a) If AUT is selected: self-equalising is configured.
- b) If M is selected: locate and select the gain level 00 – 30.

**General gain adjustment**

- 1) Locate and select the gain submenu:

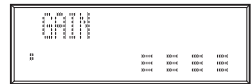

- 2) Locate and select the gain level:

- a) BI - BII input: BI\_BII, 0 - 25



- b) BIII - DAB input: BIII\_DAB, 0 - 20

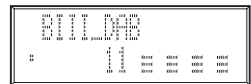

- c) VHF-UHF/EXT input: VHF\_UHF, 0 - 20



- d) UHF output: UHF, 0 - 20

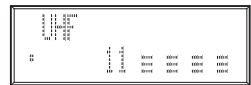

## SAT-IF output adjustment

### LNB power configuration



#### NOTE

There are 5 different configurations to select polarisation.

- 1) Locate and select polarisation:
  - a) No polarisation: LNB, OFF.
  - b) 18 V with tones: LNB, 18 V<sub>AA</sub>.
  - c) 18 V without tones: LNB, 18 V.
  - d) 13 V with tones: LNB, 13 V<sub>AA</sub>.
  - e) 13 V without tones: LNB, 13 V.



### Output gain configuration:

- 1) Locate *GA* and select level 0 - 20.

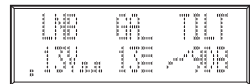

### Emphasis among high frequencies



#### NOTE

If TILT is selected, the equipment applies 9 dB of pre-emphasises.

- 1) Locate and select TILT to change the level of pre-emphasis between 0 and 9 dB.

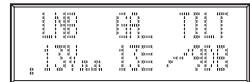

## Advanced settings

- 1) In the main menu, locate and select **ADVANCED**.



### Input preamps



#### NOTE

The gain difference between an enabled and a disabled amplifier is 20 dB. Select LO to enable an amplifier.

If the gain is set to automatic in filter configuration, the system manages preamp enabling according to the input level.

- 1) Locate and select UHF input preamps:

- a) UHF3 input:  $\Psi$ 3, HI / LO.



- b) UHF2 input: Ψ2, HI / LO.
- c) UHF1 input: Ψ1, HI / LO.

### Filters cloning



#### NOTE

Cloning begins automatically after the following steps.

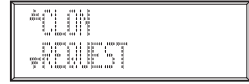

- 1) Connect two equipments using a coaxial cable in the Test 1 output of each equipment (see position **(15)** in the illustration in the [General Description](#) section on page 32).

- 2) On the equipment receiving the information: locate and select MASTER OFF, SLAVE ON.



- 3) On the equipment sending the information: locate and select MASTER ON, SLAVE OFF.



#### NOTE

The time waited for cloning to be run (step 2 to 3) is 11 seconds. Where cloning cannot be started, the equipment returns to the higher menu.

### Equipment locking



#### NOTE

The lock is enabled when the equipment is re-connected.

- 1) Enter a sequence of 4 digits (LOCK, 0000).
- 2) Locate and select LOCK, ON.



#### NOTE

To unlock the equipment, enter and select the 4-digit sequence on the start screen. To cancel equipment locking, locate and select LOCK, OFF. If you forget the 4-digit sequence see: [Troubleshooting](#) section on page 45.



## Specific equipment information



### NOTE

Information on the equipment, the programme version, the manufacturing date, the number of hours operating, the temperature and the equipment serial number are displayed on the screen.



## Restore factory values



### CAUTION

This function will mean that all previous configurations will be lost and the factory values will be restored.



- 1) Select OK to restore factory values.



## Frequency plan



### NOTE

You can choose between two different channel allocations for the UHF band. These allocations depend on the geographic territory. **By default the equipment is configured for the European allocation.**



- 1) In the advanced menu, located and select FREQUENCY PLAN.
  - a) If EUROPE is selected the channel allocation is for European standards.
  - b) If AUSTRALIAN is selected the channel allocation is for Australian standard.



## Automatic Gain Control



### NOTE

You can choose to activate the automatic gain control. **By default the equipment is configured in OFF position.**

- 1) Locate and select A.G.C. in ON position.



## Elimination of 61 to 69 channels



### NOTE

You can choose to activate the the elimination of the channels 61 to 69. **By default the equipment is configured in OFF position.**



- 1) Locate and select LTE PROTECTION in ON position.



## Outputs number configuration



### NOTE

You can choose two types of configuration for Outputs No: TV2 & TV1 or TV1.

**By default your equipment is configured for two outputs (TV1 & TV2).**

- 1) In the advanced menu, located and select OUTPUT CONFIGURATION TV2&TV1.
  - a) OUTPUT CONF TV2 & TV1 select.
  - b) OUTPUT CONF TV1 select.



## Self-installation



### NOTE

The equipment automatically configures the optimum operating frequency and gain of the UHF filters. **The equipment does not automatically configure the output level of general (band) gains.** This is because the output level must be set by the installer to suit the network you are feeding.

- 1) In the main menu, locate and select AUTOINSTALL.
  - a) If NO is selected: you will return to the main menu.
  - b) If YES is selected: self-installation will begin..



### NOTE

The equipment displays information on the status of self-installation. Please wait a few seconds until it is completed and AUTOINSTALL COMPLETED is displayed.

- 2) Select OK to complete self-installation. The unit will now show you the general (band) gain settings for adjustment.
- 3) To change the output level of general gains, see: [General gain adjustment](#) section on page 40.
- 4) To review the allocation of filters to aerials, see: [Allocation of filters to aerials](#) section on Page 38.



# Maintenance

## Equipment care



### HANDLING THE INSIDE OF THE EQUIPMENT IS FORBIDDEN

Do not dismantle or try to repair the equipment, its accessories or its components. This will render the warranty null and void.

- Do not use the power cable if it is damaged.
- To disconnect the power cable, pull carefully on the plug and not the cable.
- To clean the panel and equipment connections:
  - Unplug the equipment.
  - Clean with a slightly damp, soft cloth.
  - Allow to dry completely before use.
- Do not spill liquid onto the equipment.
- Keep ventilation slots free of dust and any foreign bodies.

## Troubleshooting

The most frequent problems arising during equipment installation are indicated below. If you encounter any other type of problem, please contact the equipment sales team.

Problem	Possible cause	What to do
Forgotten unlock code.		Contact your point of sale.
Nothing displayed on LCD screen.	The power cable is not connected properly.	Check the power cable.
The channels do not adjust to the programmed output level.	Lack of signal or unsuitable channel level.	Check that the channel programmed in the highest output channel has a signal and appropriate level. This is used as a reference for output level adjustment.
The display shows that there has been a short circuit.	Bad connection in the UHF input.	Check the input connection cables. Unplug the network connection cable and reconnect it.

# Technical specifications

## ONE 118 Model (AFP-201)

Inputs		BI-FM 1	BIII-DAB 1	UHF1	UHF2 3	UHF3
Band width	MHz	47-108	174-240		470-862	
		-	-	10	0	0
		-	-	9	0	1
Input configuration		-	-	7	0	3
Number of programmable UHF filters per input		-	-	2	5	3
		-	-	2	7	1
Gain	dB	35	40		35 / 55 (switchable)	
Gain adjustment	dB	25	20		30	
Noise figure	dB	<6	<6		<6	
Optimum input margin	dB $\mu$ V	60-85	60-80		50-80 70-100	
Return losses	dB	>10	>10		>10	
Selectivity ( $\pm$ 10 MHz of channel ends)	dB				>10	
Uncoupling between inputs	dB	-	-		>20	
AGC tolerance	dB	-	-		$\pm$ 1	
Switchable preamp voltage	V	-	-		0-12-24	
Maximum preamp current	mA	-	-		100	

Output		TV			
Output level*	dB $\mu$ V	118	118		118
Output level adjustment	dB			20	
Return losses	dB			>10	
Test outputs	dB			-30	

### Operations

Mains voltage	230 - 240 V~
Consumption	0.25 A / 25 W
Operating temperature	-5 to 50 °C
Mains connector	IEC C8

\* IMD3-60dB, DIN 45004B  
(See channel reduction table in Technical Annex)

## ONE SAT Model (AFP-292)

Inputs		BI-FM 1	BIII-DAB 1	UHF1	UHF2 3	UHF3	EXT (VHF/UHF) 1	SAT-IF 1	FI-SAT (passive) 1
Band width	MHz	47-108	174-240		470-862		47-240 / 470-862	950- 2150	950- 2150
		-	-	10	0	0	-	-	-
		-	-	9	0	1	-	-	-
Input configuration		-	-	7	0	3	-	-	-
Number of programmable UHF filters per input		-	-	2	5	3	-	-	-
		-	-	2	7	1	-	-	-
Gain	TV1&TV2 conf	30	35		35/55 (switchable)		35	40	-1.5
	TV1 conf	35	40		40/60 (switchable)		40	40	
Gain adjustment	dB	25	20		30		20	20	-
Noise figure	dB	<6	<6		<6		<6	<9	-
Optimum input margin	dB $\mu$ V	60-85	60-80		50-80 70-100		60-80	68-88	-
Return losses	dB	>10	>10		>10		>10	>10	>10
Selectivity ( $\pm$ 10 MHz of channel ends)	dB				>10		-	-	-
Uncoupling between inputs	dB	-	-		>20		-	-	-
AGC tolerance	dB	-	-		$\pm$ 1		-	-	-
Switchable preamp voltage	V	-	-		0-12-24		-	0-13-18	-
Maximum preamp current	mA	-	-		100		-	300	-
Preamp tones	kHz	-	-		-		-	0-22	-
Slope adjustment	dB	-	-		-		-	0-9	-

### Outputs (2 options)

		TV+IF						
Output level*	TV1&TV2 conf	dB $\mu$ V	113	113	118	113/118	116	-
	TV1 conf		118	118	123	113/123	116	
Output level adjustment	dB				20		-	
Return losses	dB				>10		-	
Test outputs (2)	dB				-30			

### Operations

Mains voltage	230 - 240 V~
Consumption	0.25 A / 25 W
Operating temperature	-5 to 50 °C
Mains connector	IEC C8

\* Terrestrial: IMD3-60dB, DIN 45004B ; Satellite: IMD3 -35dB, EN50083-3.  
(See channel reduction table in Technical Annex)

## ONE Home Model (AFP-HOME)

Inputs		BI-FM	UHF1
		1	1
Band width	MHz	47-108	470-862
Input configuration Number of programmable UHF filters per input		-	10
		-	9
		-	7
		-	2
		-	2
Gain	dB	-2	20 / 40 (switchable)
Gain adjustment	dB	-	30
Noise figure	dB	-	<6
Optimum input margin	dB $\mu$ V	-	50-80 70-100
Return losses	dB	>10	>10
Selectivity ( $\pm$ 10 MHz of channel ends)	dB		>10
AGC tolerance	dB	-	$\pm$ 1
Switchable preamp voltage	V	-	0-12-24
Maximum preamp current	mA	-	100
<b>Output</b>			<b>TV</b>
Output level*	dB $\mu$ V	-	113
Output level adjustment	dB	-	20
Return losses	dB	>10	
Test outputs	dB	-30	

### Operations

Mains voltage	230 - 240 V~
Consumption	0.25 A / 25 W
Operating temperature	-5 to 50 °C
Mains connector	IEC C8

\* IMD3-60dB, DIN 45004B  
(See channel reduction table in Technical Annex)

## Output level reduction in broadband amplifiers

**BROADBAND TERRESTRIAL TV AMPLIFIERS :** The RF output levels specified in this catalogue for IMD3=-60 dB (DIN 45004 B) are applicable when 2 analog TV channels are amplified. If, as is usual, more than 2 TV channels are amplified, such levels have to be reduced according to the following table:

Number of Channels (n)	2	3	4	5	6	7	8	9	10	15	20
Output level reduction	0	2	3,5	4,5	5	5,5	6	6,5	7	8,5	9,5
<b>= 7,5 · log (n-1)</b>											

**FM, DAB AND COFDM SIGNALS :** If output levels of the FM, DAB and Digital TV (COFDM) signals are adjusted 10 dB or more below the levels of the analog TV channels, those signals can be ignored when calculating the output reduction level. If referred levels are not reduced as indicated, those signals must be counted as normal channels and the output level de-rated accordingly.

**BROADBAND SATELLITE TV OR DIGITAL TERRESTRIAL TV AMPLIFIERS :** The RF output levels specified in this catalogue for IMD3=-35 dB (EN 50083-3) are applicable when 1 FM-, QPSK- or COFDM-modulated TV channel is amplified. For a bigger number of channels, such levels have to be reduced according to the following table:

Number of Channels (n)	2	3	4	5	6	7	8	9	10	15	20
Output level reduction	3	4,5	6	7	8	8,5	9	9,5	10	11,5	13
<b>= 10 · log n</b>											

**CASCADE REDUCTION :** When m same-type broadband amplifiers are laid out in cascade, an additional reduction of the output level equals 10 · log m must be taken into account for every amplifier.

## Warranty

Notwithstanding any complaints made to the direct vendor of the product, IKUSI offers equipment users a two-year warranty as of the invoice date, which shall become valid on presenting the receipt of purchase.

During the warranty period, IKUSI is responsible for any faults arising due to material or manufacturing defects and shall repair the receiver or replace it for another corresponding to the state of technology at that time. The warranty does not cover any faults or defects due to misuse or non-fulfilment of the information given in this installation manual.

All complaints other than those indicated are not included in the warranty. More specifically, the warranty does not cover services provided by the authorised vendor (e.g. installation, configuration or programme updates) or the repair of any damages or injuries caused to the client or others as a result of the installation or of receiver operations.

# Equipment recycling



## RECYCLING OF ELECTRICAL AND ELECTRONIC EQUIPMENT

**(Applicable in the European Union and in European countries with selective waste collection systems.)**

This symbol on your equipment or its packaging indicates that this product cannot be treated as general domestic waste and must be handed in at the corresponding point of collection for electric and electronic equipment. By ensuring this product is disposed of correctly you will help prevent negative consequences for the environment and human health, which could otherwise be caused by inappropriate waste handling of this product. Recycling of materials helps preserve natural resources. For more detailed information on the recycling of this product, please contact your local council, your nearest collection point or the distributor from whom you purchased the product.



# CE Certificate

By reproducing the CE marking, IKUSI guarantees equipment compliance with the corresponding harmonised standards.

## EC-Declaration of Conformity



We, Manufacturer

IKUSI, **Angel Iglesias, S.A.**  
Paseo Miramón, 170  
E-20009 San Sebastián, Spain

declare that the product

**Programmable Terrestrial&Satellite Multiband Amplifiers  
ONE**

is in conformity with

**Council Directive 2004/108/CE  
(EMC Directive)**

Standards to which conformity is declared :

**EN 50083-2** :2007

Cable networks for television signals, sound signals and interactive services. Part 2: Electromagnetic compatibility for equipment.

and

**Council Directive 2006/95/CE  
(Low Voltage Directive)**

Standards to which conformity is declared :

**EN 60728-11** :2005

Cable networks for television signals, sound signals and interactive services. Part 11: Safety.

**EN 60065** :2003

Audio, video and similar electronic apparatus. Safety requirements.



**Angel Iglesias, S.A.**

San Sebastián, March 2011

Luis Rodríguez Navarrete

— R&D Director —



Ángel Iglesias, S.A.  
Paseo Miramón, 170  
20014 San Sebastián, Spain  
Tel. +34 943 44 88 00  
Fax +34 943 44 88 20  
television@ikusi.com  
www.ikusi.com

120113E

